



Alveolar Ridge Distraction

Product Overview

Material



KLS Martin twist drills are made of stainless steel 1.4034.



KLS Martin distractors and titanium screws are made of titanium alloy (Ti-6Al-4V) according to ISO 5832-3, DIN 17851 and ASTM F136.



KLS Martin Drill-Free Screws (gold anodized) eliminate the need for drilling a pilot hole and can thus be introduced directly into the bone. All other titanium screws are self-tapping and require a pilot hole.

TC GOLD

“TC GOLD“ indicates instruments with hard metal inserts.



Describes the quantity/unit per package.

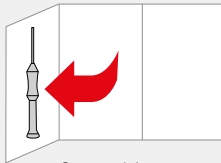

Screwdrivers turn this page

Screwdrivers and blades



25-480-99-07 25-402-99-07 25-407-03-04 25-406-99-07

25-492-98-07	⊖ 1.0 mm	x			
25-428-98-07	⊖ 1.0 mm		x		
25-431-98-07	⊖ 1.5 mm	x			
25-430-98-07	⊖ 1.5 mm		x		
25-489-97-07	⊕ 1.5 mm		x		
25-438-97-07	⊕ 1.5 mm			x	x
25-434-98-07	⊖ 2.0/2.3 mm		x		
25-540-98-07	⊖ 2.0/2.3 mm				x
25-491-97-07	⊕ 2.0/2.3 mm		x		
25-486-97-07	⊕ 2.0/2.3 mm			x	x

Bone graft screwdrivers

25-422-10-07	⊖ 1.0 mm
25-422-15-07	⊖ 1.5 mm
25-424-15-07	⊕ 1.5 mm
25-422-20-07	⊖ 2.0 mm/2.3 mm
25-424-20-07	⊕ 2.0 mm/2.3 mm

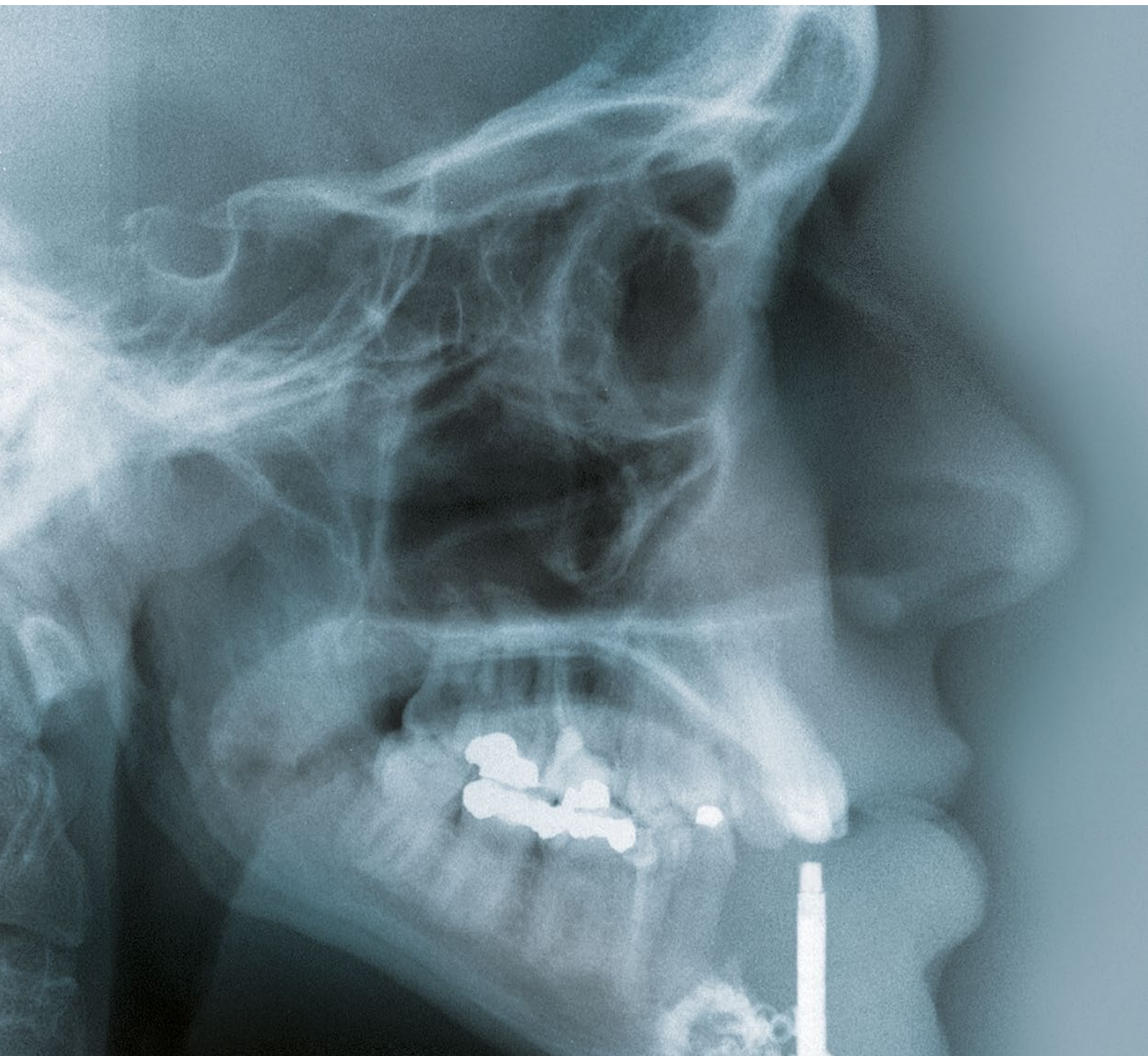

Be on the right TRACK!

The indications for alveolar ridge augmentation are acquired or congenital alveolar defects. Common aetiologies of acquired alveolar bone loss are post-extraction, traumatic avulsion of teeth, periodontal disease or after tumour resections.

Distraction in oral and cranio-maxillofacial surgery

The nature of the deficiency may present an obstacle to ideal implant positioning by compromising aesthetic and prosthetic needs.

Based on Ilizarov's technique and the pioneering work of Hidding and Zöller, vertical distraction of the alveolar ridge by especially designed distraction devices has become a state-of-the-art method for the successful treatment of such bone defects. It is considered a highly valuable technique in cases of premature teeth loss due to periodontal disease or injury, as it significantly improves the basis for substance meaning more support and better fixation of dental implants. It also ensures better aesthetic results compared to most conventional augmentation techniques.

The TRACK distractor family now provides a complete range of individual devices for the treatment of smaller partial defects of the maxillary and mandibular alveolar ridge up to the highly atrophic edentulous mandible with a huge number of clinical cases already treated all over the world. The distraction process naturally varies from patient to patient. As a rule, the entire distraction process – from insertion to removal of the device – can be completed within a period of 3-4 months.

Upon inserting the distractor, an initial latency period of 5-7 days is typically required. In the following phase, the distractor is pulled apart approx. 1 mm per day, using an activation key.

As soon as the desired bone height is achieved, the consolidation phase sets in, extending over approx. 8-12 weeks. During this period, the distractor is left in place in order to stabilize the new (but still soft) bone. When the distractor is finally removed, the dental implants are inserted simultaneously.

In this product leaflet, you will be able to find vertical distraction devices for all possible indications including their respective instruments as well as storage modules for processing all in one set.

A tiny tool,
with a great impact!



What are the advantages of alveolar process distraction?

This type of distraction actually offers quite a number of advantages, compared to traditional bone reconstruction techniques:

- There is no need to harvest bone substance from other body regions in order to graft it onto the mandible or maxilla
- No need to use artificial (bone substitute) material
- Distraction not only forms new bone substance but also increases mucosa growth, thus achieving better aesthetic results
- No further soft-tissue corrections required in most cases
- More or less painless procedure



Developed in cooperation with

Prof. Dr. Dr. J. Hidding
Dept. of Maxillofacial Surgery
Bethesda Hospital Mönchengladbach, Germany

Prof. Dr. Dr. J. E. Zöller, Dr. Dr. F. Lazar
Dept. of Maxillofacial Surgery
University Hospital Köln, Germany

Indications

- Partial defects of the mandibular and maxillar alveolar process
- Periodontal diseases with severe localized bone loss
- Localized atrophy of the alveolar ridge

Contra-Indications

- Cases of in-adequate bone volume
- Cases of in-adequate bone density
- Severe osteoporosis
- General contra-indication is the severe diseased system

Application step by step

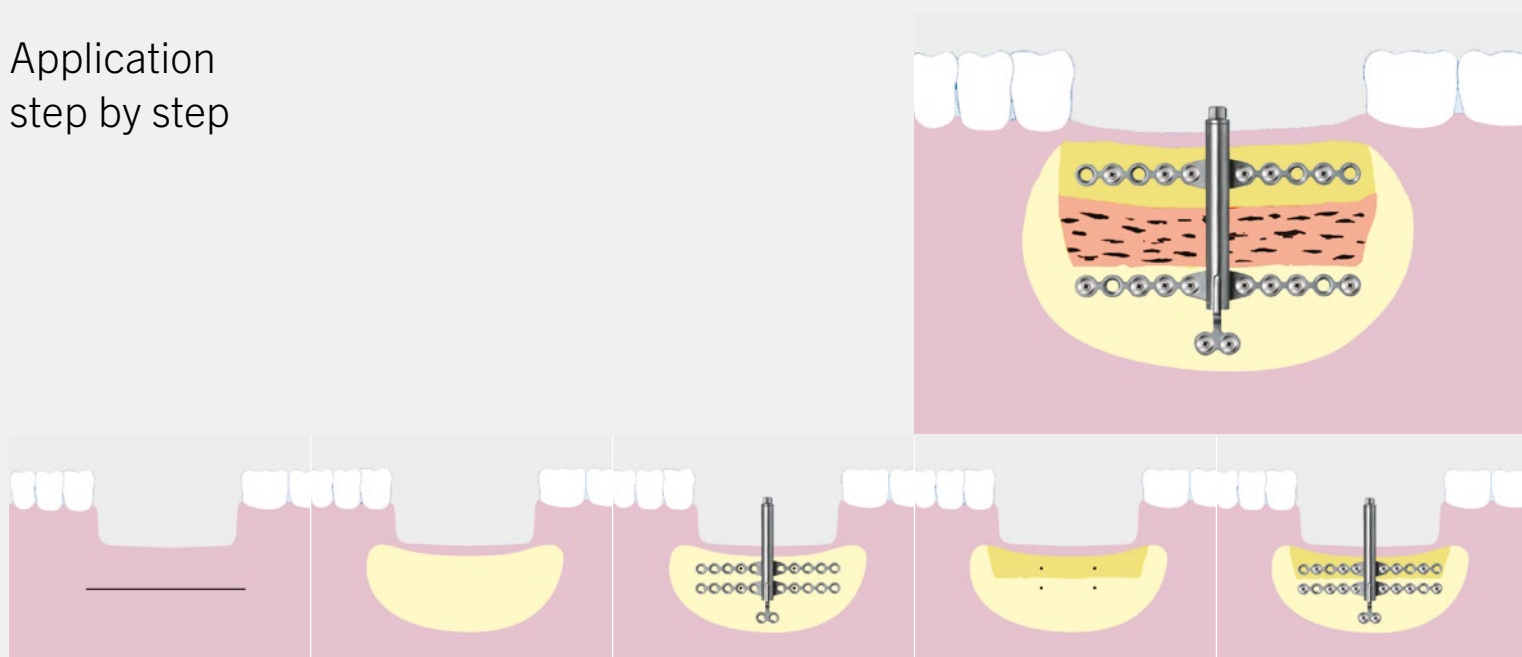

1. Depending on the defect size and localization, general or local anaesthesia should be administered.
2. After a horizontal incision in the vestibulum, a buccal mucoperiosteal flap elevation is performed exposing the lateral cortex, without elevation of the crestal mucosa.
3. The vertical distractor is placed into the desired position. The microplates are now bent carefully to the mandibular shape using the bending pliers 25-486-13-07 and 51-525-76-04 or 51-520-70-07 or 51-530-70-07. Check the correct vector of distraction and avoid any occlusal interference.
4. In this position one hole is drilled on either side of the microplates and a monocortical micro screw (4 or 5 mm) is inserted.
5. The distractor is removed again and the osteotomy line is then marked with a Lindemann burr.
6. Two vertical osteotomies are carried out using a reciprocating saw. A third horizontal osteotomy is performed apically joining the vertical component. In this manner an alveolar segmental osteotomy is achieved.
7. The segment is now entirely mobilized using fine chisels lingually. Care has to be taken of the mandibular nerve.
8. The segmental osteotomy is carried out immediately adjacent to neighbouring teeth in order to accomplish full defect coverage without damage to periodontal structure.
9. The distractor is then refixed in the same position with the screws previously used.
10. Additional screws are now inserted after drilling on the caudal and cranial side. Check and adjust the vector before placing two screws into the caudal vector stabilizing plate.
11. The function of the distractor is finally checked as well as a possible interference of the distraction rod with the occlusion.
12. The soft tissue is closed. X-ray control postoperatively is recommended.
13. After 5-7 days the distraction can start with approximately 1 mm per day (for the number of turns, please refer to the patient screwdriver).
14. A retention period of approximately 6 weeks is recommended.
15. Removal of the distractor can be performed, normally under local anaesthesia.
16. Implant insertion should be considered at the same time as distractor removal takes place.

The distractor is designed for single use only!

Small plate,
great effect!

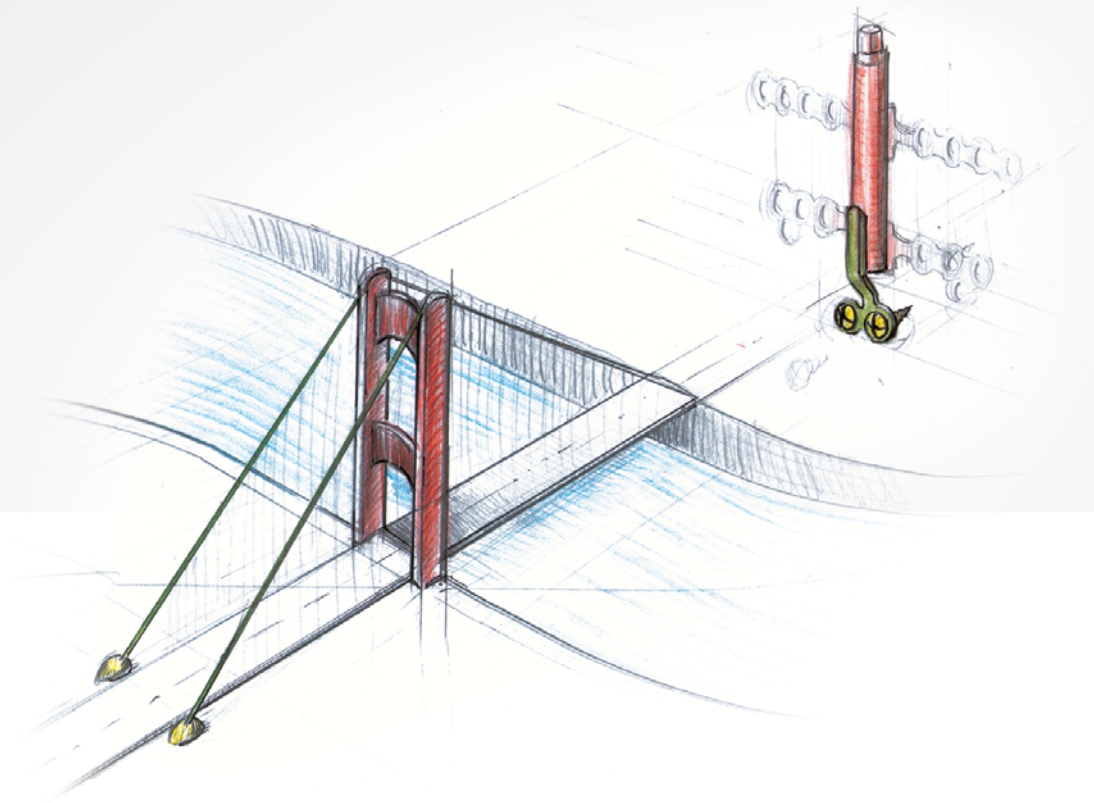

As evidenced by scientific publications and reports, lingual or palatal distraction vector tilts occurring during the distraction phase are among the most frequent complications in alveolar process distraction.

This unwelcome situation can be reliably prevented by using an additional plate at the bottom end of the distractor.

The stabilization effect thus achieved can best be illustrated comparing it to a bridge. The pier supporting the bridge corresponds to the distraction body frequently prone to tilting due to tissue pull. In like manner, the pier's stay ropes anchored in the ground correspond to the tension plate that compensates such forces.

Biomechanical test series have shown that the TRACK with an extra plate increases its stability and tilting resistance threefold, compared with TRACK models employing no extra plate.

TRACK 1.0 mm

Indications

- smaller partial defects of the maxillar and mandibular alveolar ridge



Defect, pre-operative

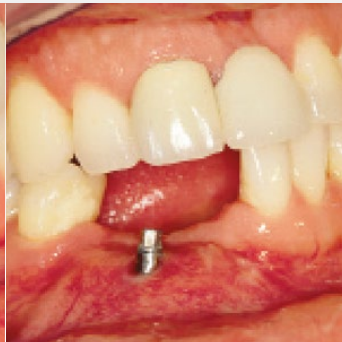

Distractor during the consolidation phase

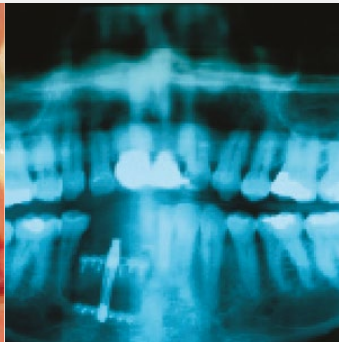

Consolidation phase

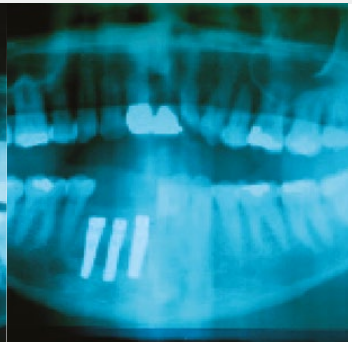

After implant placement



51-525-15-09

TRACK 1.0

distraction length 15 mm



Please note:
To avoid plate breakage during adaptation, always use the combination of bending pliers 25-486-13-07 and 51-525-76-04 or 51-520-70-07 or 51-530-70-07.

Screws and twist drills for TRACK 1.0 mm

Icon explanations

- Steel
- Titanium
- Units/pack
- Centre Drive*
- maxDrive*
- Dental attachment
- J-notch attachment

Micro screws

Ø 1.0 mm

 		Length	Centre Drive*
		4 mm	25-660-04-09
		5 mm	25-660-05-09
	6 mm	25-660-06-09	

Drill bits (dental attachment)

 		Ø x Length	Stop	Item No.
		0.8 x 50 mm	–	26-153-08-07
		0.7 x 19 mm	5 mm	50-916-05-07
		0.7 x 21 mm	7 mm	50-916-07-07

Emergency screws

Ø 1.2 mm

 		Length	Centre Drive*
		5 mm	25-661-05-09

Drill bits (J-notch attachment)

 		Ø x Length	Stop	Item No.
		0.7 x 50 mm	5 mm	25-454-05-07
		0.7 x 50 mm	5 mm	25-454-05-91
		0.7 x 50 mm	7 mm	25-454-07-07
		0.7 x 50 mm	7 mm	25-454-07-91
		for dense bone	Stop	Item No.
		0.8 x 50 mm	5 mm	25-457-05-07
		0.8 x 50 mm	5 mm	25-457-05-91
		0.8 x 50 mm	7 mm	25-457-07-91

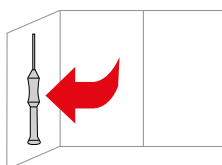

Screwdrivers
see folding page

Instruments for TRACK 1.0 mm



1/2

51-525-85-07
Patient screwdriver,
straight

St 1
units

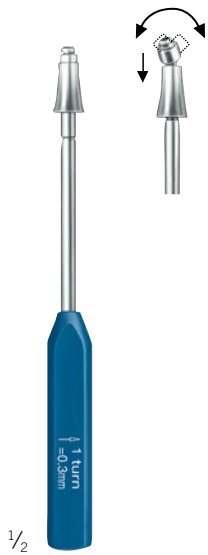

1/2

51-525-90-07
Patient screwdriver,
combination straight + angled

St 1
units



1/2

51-525-95-07
Patient screwdriver,
micro

St 1
units



1/2

25-435-10-07
16 cm/6 1/4"
Lindorf
Plate holding forceps

St 1
units



1/2

51-525-80-07
15.5 cm/6"
Plate holding forceps,
curved

St 1
units

Icon explanations

St Steel

Ti Titanium

1 unit(s) Units/pack

TC GOLD TC Instruments with hard-metal inserts



25-486-13-07
13 cm/5 1/2"
Modelling plier

St 1 unit(s) 1 unit(s)

TC GOLD

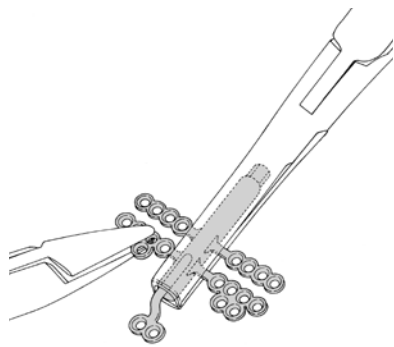

51-525-76-04
13 cm/5 1/2"
Distractor holding plier for
TRACK 1.0 mm

St 1 unit(s)



25-490-11-07
12 cm/4 3/4"
Plate cutter

St 1 unit(s)

TRACK 1Plus

Indications

- up to 3-4 teeth (35 mm) segments of the alveolar ridge

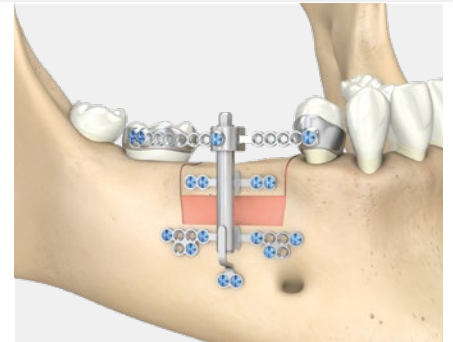
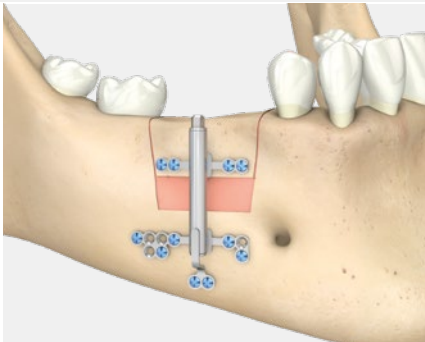

TRACK 1.0 with optional support plate 51-525-40-09



51-524-12-09
TRACK 1Plus
distraction length 12 mm



51-524-15-09
TRACK 1Plus
distraction length 15 mm



1.5-mm maxDrive® locking screw

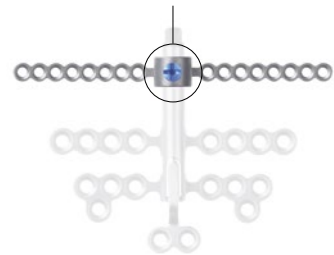

51-525-40-09
Optional support plate for
TRACK 1.0 and TRACK 1Plus



Please note:
To avoid plate breakage during adaptation, always use the combination of bending pliers 25-486-13-07 and 51-525-76-04 or 51-520-70-07 or 51-530-70-07.

The additional support plate of the TRACK 1.0 or TRACK 1 plus distractor will be fixed by 1.5-mm maxDrive® screws.

For screws and drill bits see page 9.

TRACK 1.5 mm

Indications

- wide atrophies up to 60 mm width

Icon explanations

- St Steel
- Ti Titanium
- 1 units/pack

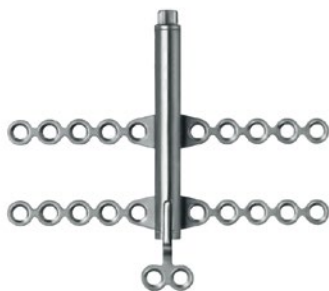
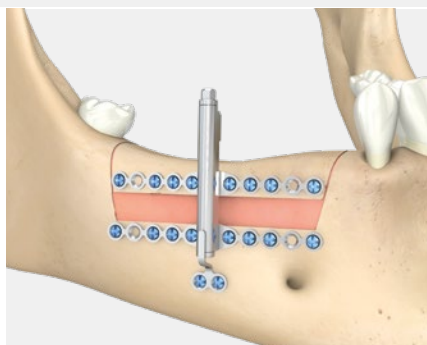
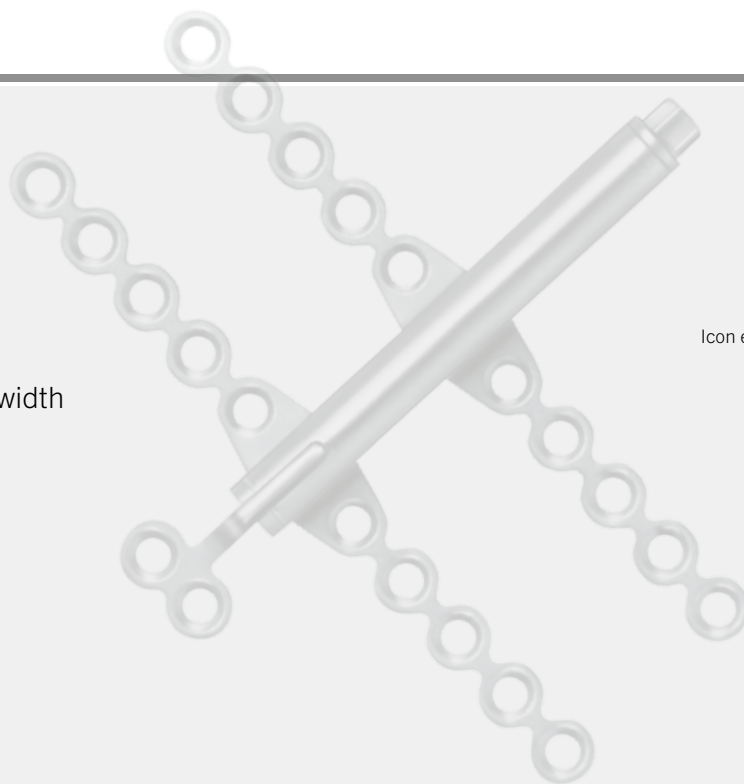

51-520-15-09

TRACK 1.5

distraction length 15 mm



Please note:

To avoid plate breakage during adaptation, always use the combination of bending pliers 25-486-13-07 and 51-525-76-04 or 51-520-70-07 or 51-530-70-07.

Screws and twist drills TRACK 1Plus and TRACK 1.5 mm



Micro screws

■ Ø 1.5 mm

		Length	Centre Drive®
		4 mm	25-665-04-09
		5 mm	25-665-05-09
		6 mm	25-665-06-09
		7 mm	25-665-07-09

■ Ø 1.5 mm

		Length	maxDrive®
		4 mm	25-875-04-09
		5 mm	25-875-05-09
		6 mm	25-875-06-09
		7 mm	25-875-07-09

Emergency screws

■ Ø 1.8 mm

		Length	Centre Drive®
		5 mm	25-666-05-09
		7 mm	25-666-07-09

■ Ø 1.8 mm

		Length	maxDrive®
		4 mm	25-876-04-09
		5 mm	25-876-05-09
		7 mm	25-876-07-09

Drill-Free screws

■ Ø 1.5 mm









		Length	Centre Drive®
		4 mm	25-668-04-09
		5 mm	25-668-05-09
		6 mm	25-668-06-09

■ Ø 1.5 mm





		Length	maxDrive®
		4 mm	25-878-04-09
		5 mm	25-878-05-09
		6 mm	25-878-06-09



Icon explanations

-  Steel
-  Titanium
-  Units/pack
-  Centre Drive*
-  maxDrive*
-  Dental attachment
-  J-notch attachment
-  Cylindrical attachment

Drill bits (dental attachment)

 	Ø x Length	Stop	Item No.
	1.1 x 20 mm	7 mm	50-920-07-07 

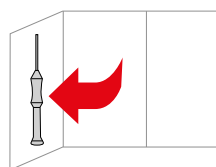





Screwdrivers
see folding page

Drill bits (J-notch attachment)

 	Ø x Length	Stop	Item No.
	1.1 x 50 mm	–	25-452-00-07 
	1.1 x 50 mm	–	25-452-00-91 
	1.1 x 50 mm	5 mm	25-452-05-07 
	1.1 x 50 mm	5 mm	25-452-05-91 
	1.1 x 50 mm	7 mm	25-452-07-07 
	1.1 x 50 mm	7 mm	25-452-07-91 

Milling cutter

 	Ø x Length	Stop	Item No.
	1.1 x 45 mm	11 mm	38-051-45-07 

Instruments for TRACK 1Plus and TRACK 1.5 mm



51-525-85-07
Patient screwdriver,
straight,
for TRACK 1Plus

St 1
unit(s)



51-525-90-07
Patient screwdriver,
combination
straight + angled,
for TRACK 1Plus

St 1
unit(s)



51-525-95-07
Patient screwdriver,
micro,
for TRACK 1Plus

St 1
unit(s)



51-500-90-07
Patient screwdriver,
straight,
for TRACK 1.5 mm

St 1
unit(s)



51-505-90-07
Patient screwdriver,
angled,
for TRACK 1.5 mm

St 1
unit(s)



51-520-95-07
Patient screwdriver,
micro,
for TRACK 1.5 mm

St 1
unit(s)

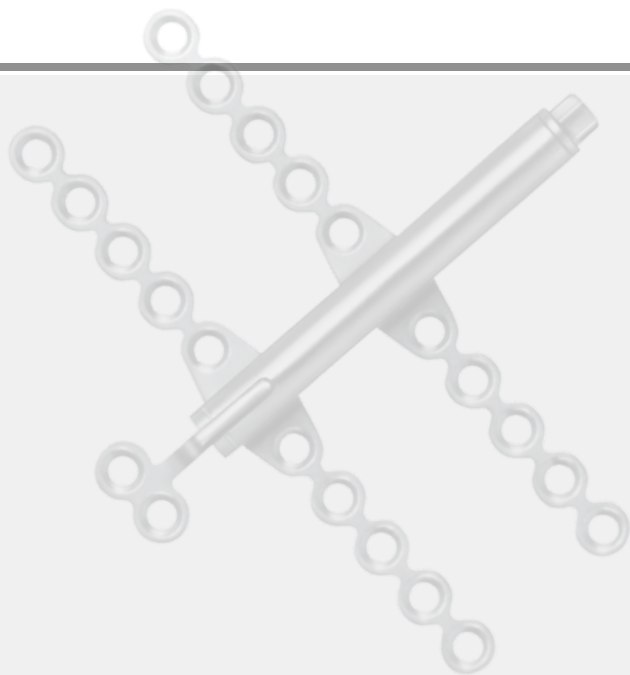

Icon explanations

- St Steel
- Ti Titanium
- 1 Units/pack

TC GOLD TC Instruments with hard-metal inserts

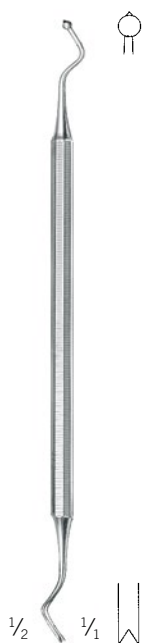

25-435-15-07
18 cm/7"
Lindorf
Plate holding forceps

St 1 unit(s)



51-525-80-07
15.5 cm/6"
Plate holding
forceps, curved

St 1 unit(s)

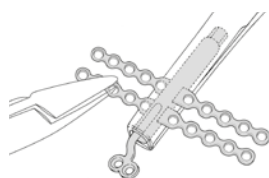

25-486-13-07
13 cm/5 1/2"
Modelling plier

St 1 unit(s)

TC GOLD



51-525-76-04
13 cm/5 1/2"
Distractor holding plier
for TRACK 1Plus

St 1 unit(s)



51-520-70-07
13 cm/5 1/2"
Distractor holding plier
for TRACK 1.5 mm

St 1 unit(s)



25-490-11-07
12 cm/4 1/2"
Plate cutter

St 1 unit(s)

TRACK 2.0

Indications

- highly atrophic and edentulous mandibles in the front section

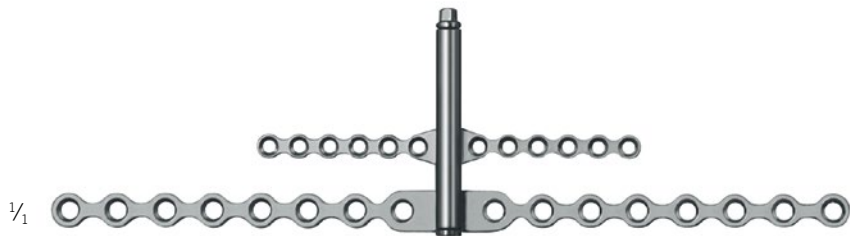
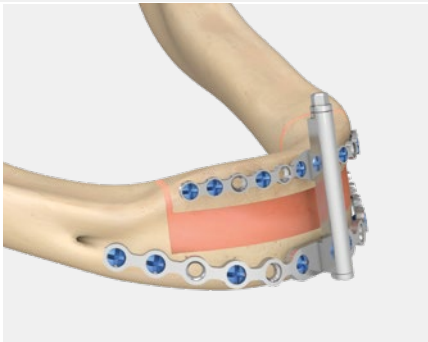

51-530-15-09
TRACK 2.0
distraction length 15 mm







Please note:

To avoid plate breakage during adaptation, always use the combination of bending pliers 25-486-13-07 and 51-525-76-04 or 51-520-70-07 or 51-530-70-07.

1.5 mm screws for TRACK 2.0 for transport plate

Icon explanations

-  Steel
-  Titanium
-  1 unit(s)
-  Centre Drive®
-  maxDrive®

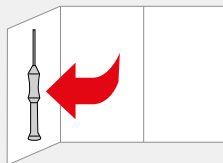



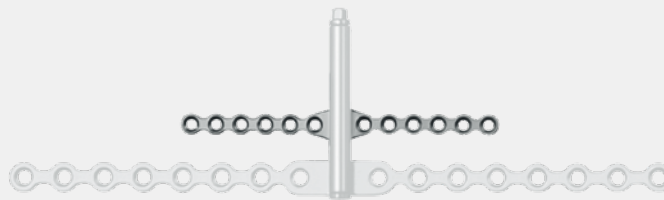

Screwdrivers
see folding page







Micro screws

 Ø 1.5 mm





 		Length	Centre Drive® 
		4 mm	25-665-04-09
		5 mm	25-665-05-09
		6 mm	25-665-06-09
		7 mm	25-665-07-09

 Ø 1.5 mm





 		Length	maxDrive® 
		4 mm	25-875-04-09
		5 mm	25-875-05-09
		6 mm	25-875-06-09
		7 mm	25-875-07-09

Emergency screws

 Ø 1.8 mm





 		Length	Centre Drive® 
		5 mm	25-666-05-09
		7 mm	25-666-07-09

 Ø 1.8 mm





 		Length	maxDrive® 
		4 mm	25-876-04-09
		5 mm	25-876-05-09
		7 mm	25-876-07-09

Drill-Free screws

 Ø 1.5 mm

 		Length	Centre Drive® 
		4 mm	25-668-04-09
		5 mm	25-668-05-09
		6 mm	25-668-06-09

 Ø 1.5 mm

 		Length	maxDrive® 
		4 mm	25-878-04-09
		5 mm	25-878-05-09
		6 mm	25-878-06-09

2.0 mm screws for TRACK 2.0 for base plate

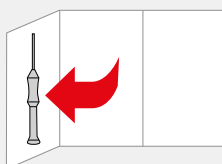

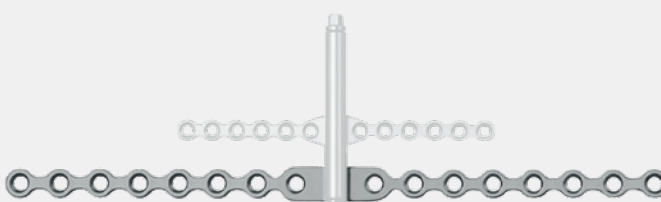

Screwdrivers
see folding page





Mini screws

■ Ø 2.0 mm



	Length	Centre Drive* 
	5 mm	25-662-05-09
	6 mm	25-662-06-09
	7 mm	25-662-07-09

■ Ø 2.0 mm



	Length	maxDrive* 
	5 mm	25-872-05-09
	6 mm	25-872-06-09
	7 mm	25-872-07-09

Emergency screws

▨ Ø 2.3 mm



	Length	Centre Drive* 
	5 mm	25-663-45-09
	7 mm	25-663-47-09

▨ Ø 2.3 mm



	Length	maxDrive* 
	5 mm	25-873-45-09
	7 mm	25-873-47-09

Drill-Free screws

■ Ø 2.0 mm

	Length	Centre Drive* 
	5 mm	25-669-05-09
	7 mm	25-669-07-09









■ Ø 2.0 mm

	Length	maxDrive* 
	5 mm	25-879-05-09
	6 mm	25-879-06-09
	7 mm	25-879-07-09









Twist drills

1.5 and 2.0 mm screws





Icon explanations

-  St Steel
-  Ti Titanium
-  1 unit(s) Units/pack
-  Centre Drive®
-  maxDrive®
-  Dental attachment
-  J-notch attachment
-  Cylindrical attachment









Drill bits for 1.5 mm screws (J-notch attachment)

 	Ø x Length	Stop	Item No.
	1.1 x 50 mm	–	25-452-00-07 
	1.1 x 50 mm	–	25-452-00-91 
	1.1 x 50 mm	5 mm	25-452-05-07 
	1.1 x 50 mm	5 mm	25-452-05-91 
	1.1 x 50 mm	7 mm	25-452-07-07 
	1.1 x 50 mm	7 mm	25-452-07-91 



Drill bits for 1.5 mm screws (dental attachment)

 	Ø x Length	Stop	Item No.
	1.1 x 20 mm	7 mm	50-920-07-07 





Drill bits for 2.0 mm screws (J-notch attachment)

 	Ø x Length	Stop	Item No.
	1.5 x 50 mm	–	25-449-05-07 
	1.5 x 50 mm	–	25-449-05-91 
	1.5 x 50 mm	5 mm	25-449-05-07 
	1.5 x 50 mm	5 mm	25-449-05-91 
	1.5 x 50 mm	7 mm	25-449-05-07 
	1.5 x 50 mm	7 mm	25-449-05-91 

Drill bits for 2.0 mm screws (dental attachment)

 	Ø x Length	Stop	Item No.
	1.5 x 20 mm	7 mm	50-924-07-07 

Milling cutter

 	Ø x Length	Stop	Item No.
	1.1 x 45 mm	11 mm	38-051-45-07 

Instruments for TRACK 2.0 mm



1/2

51-500-90-07
Patient screwdriver,
straight,
for TRACK 1.5 mm

St 1
unit(s)



1/2

51-505-90-07
Patient screwdriver,
angled,
for TRACK 1.5 mm

St 1
unit(s)



1/2

51-520-95-07
Patient screwdriver,
micro,
for TRACK 1.5 mm

St 1
unit(s)

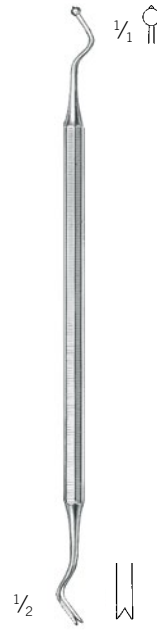

1/2

25-435-15-07
18 cm/7"
Lindorf,
Plate holding forceps

St 1
unit(s)



1/2

51-525-80-07
15.5 cm/6"
Plate holding forceps,
curved

St 1
unit(s)

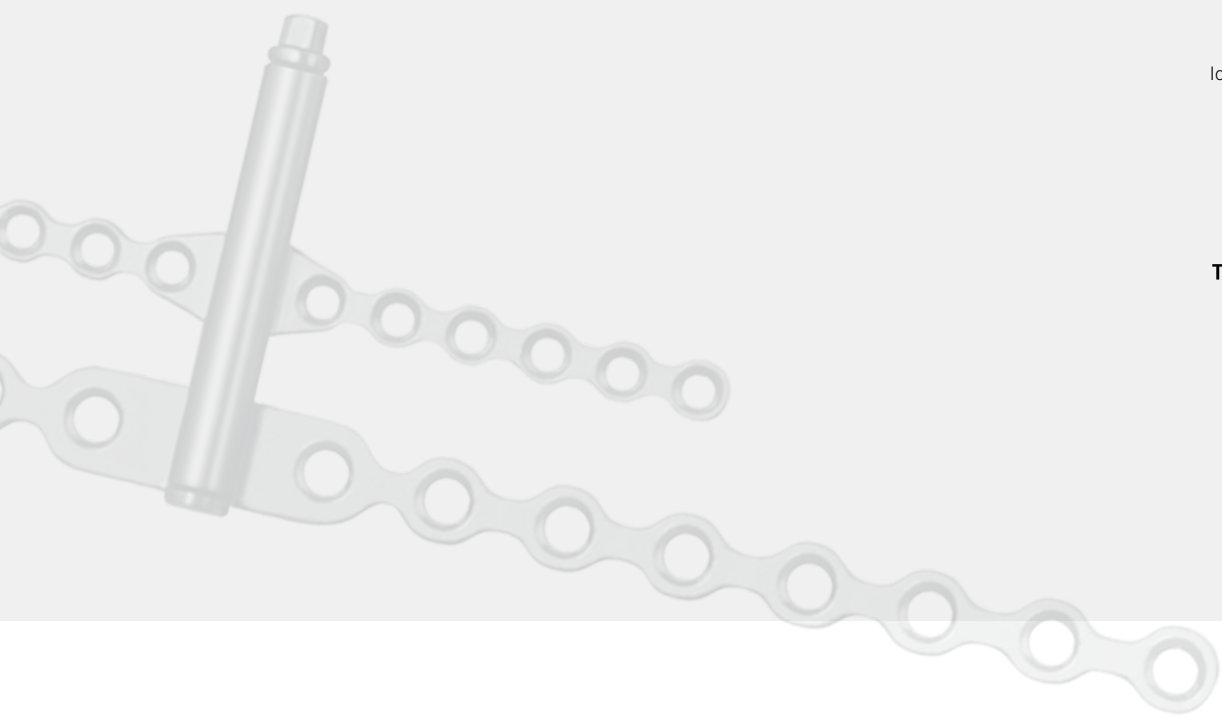

Icon explanations

St Steel

Ti Titanium

1 unit(s) Units/pack

TC GOLD TC Instruments with hard-metal inserts

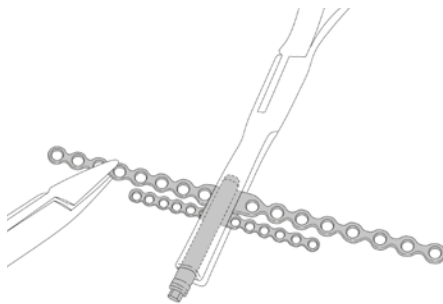

25-486-13-07
13 cm/5 1/2"
Modelling plier

51-530-70-07
13 cm/5 1/2"
Distractor holding plier
for TRACK 2.0 mm

25-420-16-07
16 cm/6 1/2"
Plate cutter

St 1 unit(s)

TC GOLD

St 1 unit(s)

St 1 unit(s)

TC GOLD

Storage modules



Bone graft kit

Category	Scope	Item Number
Bone graft kit	complete	50-700-00-04

consisting of:		
Insert module, grey	separate	55-962-07-04
Insert bone graft kit	separate	55-964-28-04
Lid bone graft kit	separate	55-963-28-04

Distraction module

Category	Scope	Item Number
Insert module, purple	separate	55-962-08-04
Storage module, purple	separate	55-962-18-04
Lid for distraction module	separate	55-963-17-04
Lid storage module	separate	55-963-09-04
Insert f. TRACK distractors	separate	55-964-23-04
Insert universal	separate	55-964-17-04

Going deeper ... Literature

1. Ackermann K.-L., Kirsch A., Neuendorff G., Filderstadt H., Nagel R.:
Alveolarkammdefekte behandeln –
Knochen und Weichgewebe werden simultan erweitert:
Alveolarkamm distraction in der anterioren Maxilla
DZW-Spezial, Zahnmedizin, 5(2002), 55-58
2. Bier A.:
Über Knochenregeneration und über Pseudarthrosen
Arch f Klein Chir 127, 1 (1927)
3. Block M.S.: Chang A., Crawford C.:
Mandibular alveolar ridge augmentation in the dog
using distraction Osteogenesis
J. Oral Maxillofacial Surgery 54(3), 309-14 (1996)
4. Chiapasco M., Brusati R., Galioto S.:
Distraction Osteogenesis of a Fibular Revascularized
Flap for Improvement of Oral Implant Positioning in a
Tumor Patient – A Case Report
J. Oral Max.Fac Surgery 58 (2000), 1434-1440
5. Chiapasco M., Romeo E., Vogel G.:
Vertical Distraction Osteogenesis of Edentulous Ridges
For Improvement of Oral Implant Positioning –
A Clinical Report of Preliminary Results
Int. J. of Oral & Max.Fac Implants, Volume 16, Nr. 1
(2001)
6. Chin M., Toth, B.A.:
Distraction Osteogenesis in Maxillofacial Surgery Using
Internal Devices
J. Oral Maxillofacial Surgery 54 45 – 53 (1996)
7. Dausse T., Laffargue P., Jaquet N.:
Intérêt de la Distraction Alvéolaire Pré-Implantaire dans
les Reconstructions Maxillo-Faciales Complexes
Revue trimestrielle d'implantologie orale XX (XXXX) 37-40
8. Gabriele A. Millesi-Schobel, Millesi W., Glaser C.,
Watzinger F., Klug C., Ewers R.:
The L-shaped osteotomy for vertical callus distraction
in the molar region of the mandible
J. Cranio Max.Fac Surgery 28 (2000), 176-180
9. Hidding J., Lazar F., Zöller J. E.:
The Vertical Distraction of the Alveolar Bone
J. Cranio Max.Fac Surgery 26, Suppl 1, (1998), 72-73
10. Hidding J., Zöller J. E.:
Alveolar Bone Distraction
Atlas of Craniomaxillofacial Osteogenesis
Miniplates, Microplates and Screws
Ed.: F. Härle, M. Champy and B. Terry
Thieme Stuttgart New York (1999)
11. Hidding J., Lazar F., Zöller J. E.:
Erste Ergebnisse bei der Distractionsosteogenese
des atrophischen Alveolarkamms
Mund Kiefer GesichtsChir 3, Suppl (1999)
12. Hidding J., Lazar F., Zöller J. E.:
Knöcherne Regeneration des Unterkieferalveolarfortsatzes
mit Hilfe der vertikalen Kallusdistraction
Deutsch Zahnärztl. Z. 54 (1999), 51-54
13. Hoffmann M.:
Die vertikale Alveolarkamm distraction –
Vorgehen, Prognose
BZB 5(2003) BLZK & KZVB
14. Hoffmann M.:
Die Atrophie des Kieferkamms –
Vom Knochen transfer zur Kallusdistraction
ZMK 18, 9(2002), 572-580

Going deeper ... Literature

15. Ilizarov, G.A.:
Basic principles of transosseous compression and distraction osteosynthesis
Orthop Travmatol Protez 30, 7 (1971)
16. Ilizarov G.A.:
The Principles of the Ilizarov Method
Bull. Hospital Joint Dis. Orthop. Inst. 48, 1 (1988)
17. Ilizarov G.A.:
The tension-stress effect on the genesis and growth of tissues: part I.
The influence of stability of fixation and soft tissue preservation
Clin. Orthop. 238 (1989a), 249-281
18. Ilizarov G.A.:
The tension-stress effect on the genesis and growth of tissues: part II.
The influence of the rate and frequency of distraction
Clin. Orthop. 239 (1989b), 263-285
19. Khoury F.:
Augmentation osseuse et chirurgie implantaire
Implant, Volume 5, Numéro 4 (1999)
20. Klesper B., Lazar F., Siessegger M., Hidding J., Zöller J. E.:
Vertical distraction osteogenesis of fibula transplants for mandibular reconstruction
J. Cranio Max.Fac Surgery 10(2002); 30 (5)
21. Klug C., Gabriele A. Millesi-Schobel, Millesi W., Watzinger F., Ewers R.:
Preprosthetic Vertical Distraction Osteogenesis of the Mandible Using an L-Shaped Osteotomy and Titanium Membrane for Guided Bone Regeneration
J. Oral Maxillofacial Surgery 59 (2001), 1302-1308
22. Lazar F., Zöller J. E., Hidding J.:
Die vertikale Kieferkammdistraktion – Eine neue Operationstechnik zum Aufbau des höhen-geminderten Kieferknochens vor der Implantation
Implantologie 3(2000), 255-265
23. Lazar F., Zöller J. E., Hidding J.:
Mikro- und Makrodistraktion am Kiefer – Eine sichere Methode der Knochengewinnung
Mund Kiefer Gesichtschir 4, Suppl 2 (2000), 432-437
24. Neugebauer J., Lazar F., Hidding J., Kübler A., Zöller J. E.:
Mise en Place d'Implants après Distraction Osseuse sur des Patients Atteints de Défauts Osseux d'Origine Tumorale
Revue trimestrielle d'implantologie orale 44 (2002), 29-33
25. Robiony M., Polini F., Costa F., Politi M.:
Osteogenesis Distraction and Platelet-Rich Plasma for Bone Restoration of the Severely Atrophic Mandible
J. Oral Maxillofac Surgery 60 (2002), 630-635

The natural way for jawbone reconstruction

Distraction – a new procedure for achieving
perfect results in implantology

Operated on: _____

Start of distraction: _____

Rotations per day: _____

Questions? – Telephone No.: _____

Further Doctor's orders: _____

Please observe arrow direction
when operating the distractor!

TRACK 1.0 / 1 Plus: 0.3 mm / rotation

TRACK 1.5 / 2.0: 0.5 mm / rotation

Day	1	2	3	4	5	6	7	8	9	10	11	12	13	14	15
Rotations 1															
2															
3															



The natural way for jawbone reconstruction

What does “distraction” mean?

Distraction osteogenesis is a technique for lengthening or reconstructing bones that utilizes the self-healing forces of the human body. In this process, new bone tissue (so-called callus) starts forming between two separate bone pieces as they are slowly pulled apart. To pull the two bone sections apart, a small distraction apparatus is employed, which is fitted to the jawbone and needs to be activated by you on a daily basis.

Distraction involves different phases, to be such as:

- Latency phase:** Means the time period between the surgical intervention and the beginning of the distraction.
- Distraction phase:** The time period during which distraction takes place at a rate of approx. 1 mm per day.
- Consolidation phase:** The time period required for the bone to heal and ossify. This phase is completed when the distractor is removed.

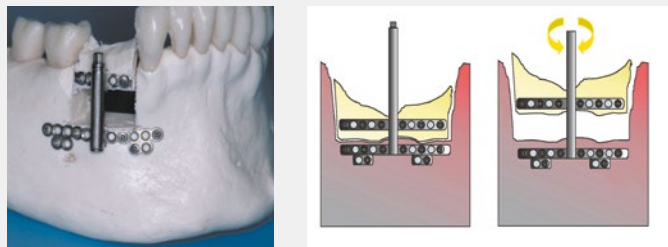
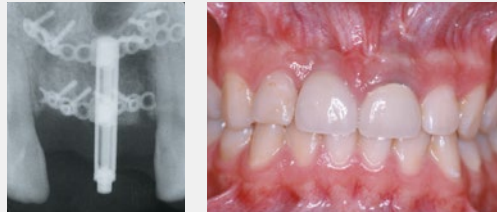

What does “alveolar process distraction” mean – and how does it work?

Alveolar process distraction achieves the vertical lengthening (reconstruction) of the maxilla or mandible. This represents a highly valuable technique in cases of premature teeth loss due to periodontal disease or injury, as it significantly improves the basis for subsequent prosthetic treatment. In any case, more bone substance means more support and better fixation of dental implants and also ensures better aesthetic results.

How long will the distraction process take?

This naturally varies from patient to patient. As a rule, the entire distraction process – from insertion to removal of the device – can be completed within a period of 3-4 months.

Upon inserting the distractor, an initial latency period of 5-7 days is typically required. In the following distraction phase, the distractor is pulled apart approx. 1 mm per day, using an activation key.

As soon as the desired bone height is achieved, the consolidation phase sets in, extending over approx. 8-12 weeks. During this period, the distractor is left in place in order to stabilize the new (but still soft) bone. When the distractor is finally removed, the dental implants are inserted simultaneously.

Make sure you always follow your doctor's instructions, as these could differ from this general, rough-and-ready description.



What are the advantages of alveolar process distraction?

This type of distraction actually offers quite a number of advantages, compared to traditional bone reconstruction techniques:

- There is no need to harvest bone substance from other body regions in order to graft it onto the mandible or maxilla.
- No need to use artificial (bone substitute) material.
- Distraction not only forms new bone substance but also increases mucosa growth, thus achieving better aesthetic results.
- No further soft-tissue corrections required in most cases.
- More or less painless procedure.

What needs to be observed during the therapy?

- Always comply fully with your doctor's instructions.
- Be sure to follow a soft diet during the entire distraction period.
- Careful oral hygiene is indicated during the entire treatment.
- Smoking can impair distraction results. So never smoke during the treatment!

Who can benefit from alveolar process distraction?

Patients of all age groups suffering from a lack of bone substance in the maxilla or mandible; patients with orthodontic conditions such as ankylosed teeth or open bite.

For the following patient groups, a distraction failure cannot be ruled out:

- diabetics
- patients with osteoporosis
- patients with an immune deficiency
- patients having undergone radiation treatment



If you still have any questions ...
... we will be glad to answer them anytime.

You can reach us personally, either by e-mail
or through our customer hotline.

Customer hotline: +49-7461-706-0
E-mail: info@klsmartin.com
Internet: www.klsmartin.com

Additional product brochures and information materials

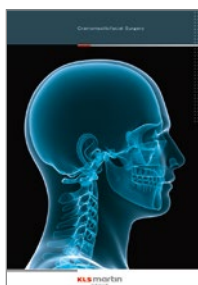

Folder system
Craniomaxillofacial
surgery



General catalog



Dental catalog



Patient leaflet for details
(available in German
and English)

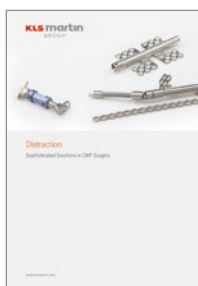

Distraction
product overview



SonicWeld Rx®
Restoring nature

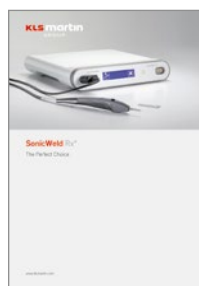

SonicWeld Rx® overview
The perfect choice

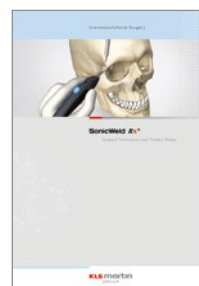

SonicWeld Rx® overview
Surgical techniques
and product range



SonicWeld Rx®
CD-ROM

CMF Surgery

SonicWeld Rx®

Resorbable implants for use in craniomaxillofacial osteosynthesis

- Resorb x®
- Resorb xG

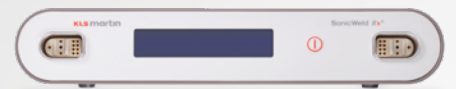

It is the face that makes humans unique and unmistakable – “There is nothing that more closely reflects the life of an individual than the human face*.”

Our objective is to simplify craniofacial surgery with specially designed implant systems that ensure optimum satisfaction for both surgeon and patient. Together with renowned users we translate new ideas into innovative products and are constantly enhancing them.

Our range of products includes everything necessary for modern craniofacial surgery. We not only set standards but we also go beyond to take advantage of modern technology in the development of solutions customized for the individual patient.

KLS Martin – your competent and reliable partner for both everyday challenges and special challenges.

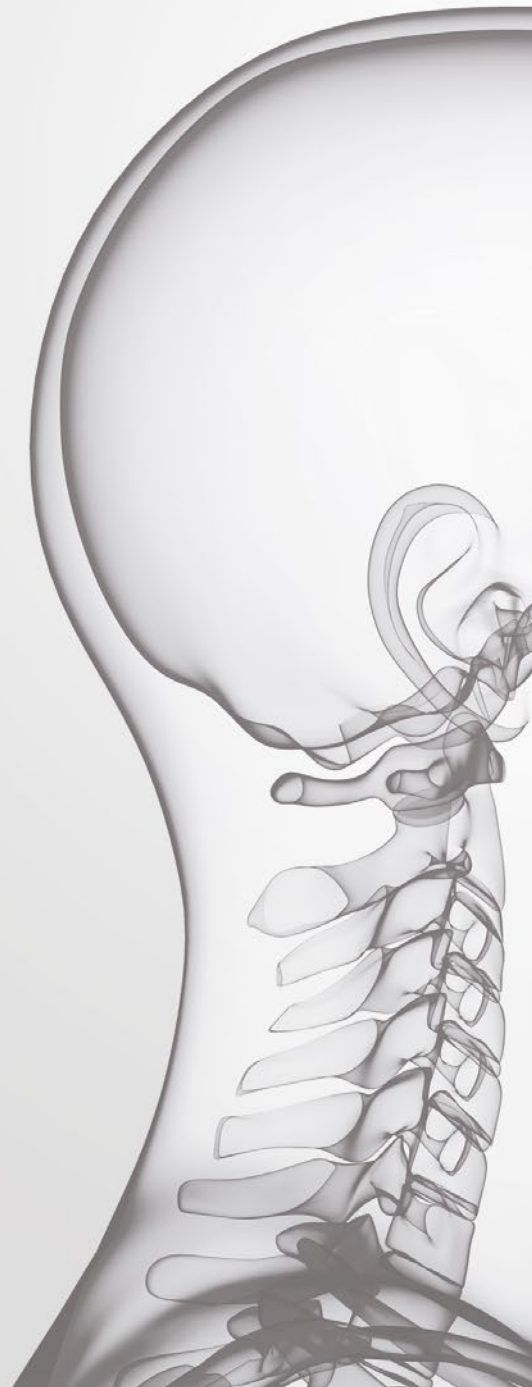

* © Kurt Haberstich (*1948)

Distractors

Devices for use in correction of malformations

- Cranial distraction
- Midface distraction
- Mandibular distraction



Individual Patient Solutions

Patient-specific solutions for use in craniomaxillofacial surgery

- IPS Implants®
- IPS CaseDesigner®
- IPS Gate®



LevelOne Fixation

Titanium implants and instruments for use in craniomaxillofacial osteosynthesis

- Traumatology
- Reconstruction
- Orthognatic surgery



App for CMF products

All important information about the CMF portfolio at one glance.

Available on the App Store iOS



GET IT ON Google play Android



KLS Martin Group

KLS Martin Australia Pty Ltd.

Sydney · Australia
Tel. +61 2 9439 5316
australia@klsmartin.com

KLS Martin do Brasil Ltda.

São Paulo · Brazil
Tel. +55 11 3554 2299
brazil@klsmartin.com

KLS Martin Medical (Shanghai) International Trading Co. Ltd.

Shanghai · China
Tel. +86 21 5820 6251
china@klsmartin.com

KLS Martin India Pvt Ltd.

Chennai · India
Tel. +91 44 66 442 300
india@klsmartin.com

Martin Italia S.r.l.

Milan · Italy
Tel. +39 039 605 67 31
italia@klsmartin.com

Nippon Martin K.K.

Tokyo · Japan
Tel. +81 3 3814 1431
nippon@klsmartin.com

KLS Martin SE Asia Sdn. Bhd.

Penang · Malaysia
Tel. +604 505 7838
malaysia@klsmartin.com

KLS Martin de México S.A. de C.V.

Mexico City · Mexico
mexico@klsmartin.com

Martin Nederland/Marned B.V.

Huizen · The Netherlands
Tel. +31 35 523 45 38
nederland@klsmartin.com

Gebrüder Martin GmbH & Co. KG

Moscow · Russia
Tel. +7 499 792-76-19
russia@klsmartin.com

KLS Martin Taiwan Ltd.

Taipei 106 · Taiwan
Tel. +886 2 2325 3169
taiwan@klsmartin.com

Gebrüder Martin GmbH & Co. KG

Dubai · United Arab Emirates
Tel. +971 4 454 16 55
middleeast@klsmartin.com

KLS Martin UK Ltd.

London · United Kingdom
Tel. +44 1189 000 570
uk@klsmartin.com

KLS Martin LP

Jacksonville · Florida, USA
Tel. +1 904 641 77 46
usa@klsmartin.com

Gebrüder Martin GmbH & Co. KG

A company of the KLS Martin Group

KLS Martin Platz 1 · 78532 Tuttlingen · Germany
P.O. Box 60 · 78501 Tuttlingen · Germany
Tel. +49 7461 706-0 · Fax +49 7461 706-193
info@klsmartin.com · www.klsmartin.com

